

DENTAL UNIT

CLESTA II

INSTALLATION INSTRUCTIONS

IMPORTANT

**This manual provides installation instructions for the CLESTA-II.
The instructions contained in this booklet should be thoroughly read and understood before installing the chair and unit.
After the installation has been completed, keep this manual in a safe place and refer to it for future maintenance.**



TABLE OF CONTENTS

	Page
1. OVERALL VIEW AND MAJOR COMPONENTS	
1-1. CHAIR SECTION OVERALL VIEW AND MAJOR COMPONENTS -----	1
1-2. UNIT SECTION OVERALL VIEW AND MAJOR COMPONENTS -----	2
2. DIMENSIONS AND SPECIFICATIONS	
2-1. CHAIR SECTION DIMENSIONS -----	3
2-2. CHAIR SECTION SPECIFICATIONS -----	3
2-3. UNIT SECTION DIMENSIONS -----	4
2-4. UNIT SECTION SPECIFICATIONS -----	4
3. REQUIREMENTS FOR INSTALLATIONS-----	5
4. CHAIR SECTION PREPARATION FOR INSTALLATIONS	
4-1. CHAIR SECTION UNPACKING -----	9
4-2. CHAIR SECTION PREPARATION FOR INSTALLATIONS-----	9
5. UNIT SECTION PREPARATION FOR INSTALLATIONS	
5-1. UNIT SECTION UNPACKING-----	11
5-2. UNIT SECTION PREPARATION FOR INSTALLATIONS-----	12
6. INSTALLATIONS INSTRUCTIONS	
6-1. MOUNTING CUSPIDOR UNIT ON TO THE CHAIR -----	13
6-2. FIXING UNIT HOSES TO THE CHAIR-----	14
6-3. INSTALLATION OF UTILITY SECTION -----	14
6-4. INSTALLATION OF DENTAL LIGHT -----	17
6-5. CHAIR ASSEMBLY-----	18
6-6. UNIT ASSEMBLY -----	20
7. ADJUSTMENT	
7-1. UNIT SECTION ADJUSTMENT-----	21
7-2. HANDPIECE ADJUSTMENT -----	21
7-3. HANDPIECE HOLDER ADJUSTMENT-----	22
7-4. CHAIR SECTION ADJUSTMENT-----	22
8. CHAIR HYDRAULIC DIAGRAM -----	23
9. CHAIR ELECTRICAL DIAGRAM-----	24
10. UNIT FLOW DIAGRAM -----	25
11. UNIT ELECTRICAL DIAGRAM -----	26

1. OVERALL VIEW AND MAJOR COMPONENTS

1-1. CHAIR SECTION OVERALL VIEW AND MAJOR COMPONENTS

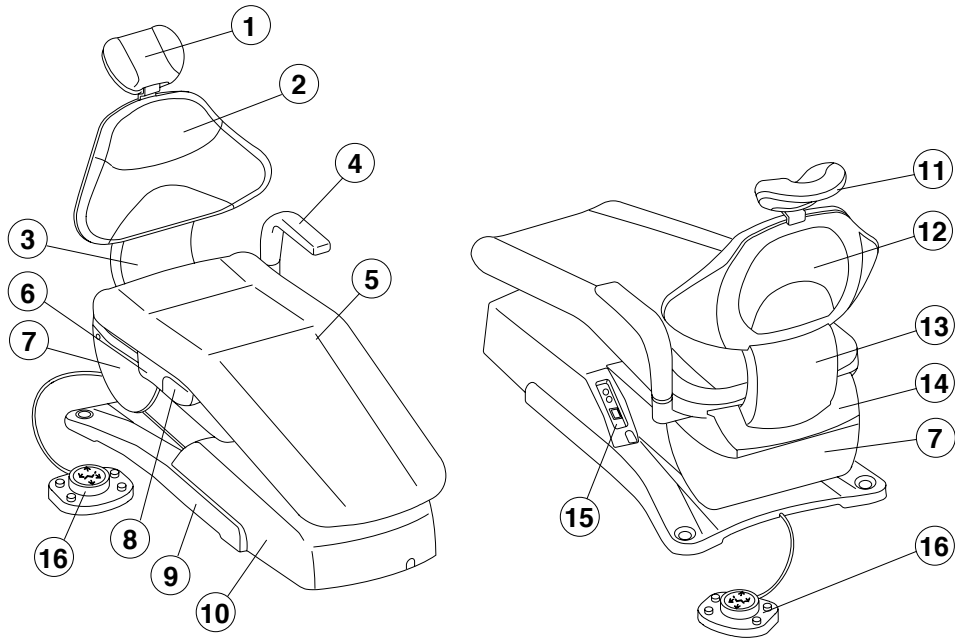

Fig.1-1 Chair Section Overall View

Chair Section Major Components

- | | |
|------------------------|--------------------------|
| (1) Headrest | (11) Headrest Rear Cover |
| (2) Backrest | (12) Backrest Rear Cover |
| (3) Back Support | (13) Back Support Cover |
| (4) Armrest (Left) | (14) Upper Flange Cover |
| (5) Seat | (15) Main Switch Panel |
| (6) Flange | (16) Foot Control |
| (7) Lower Flange Cover | |
| (8) Flange Hose Cover | |
| (9) Base | |
| (10) Pump Cover | |

1-2. UNIT OVERALL VIEW AND MAJOR COMPONENTS

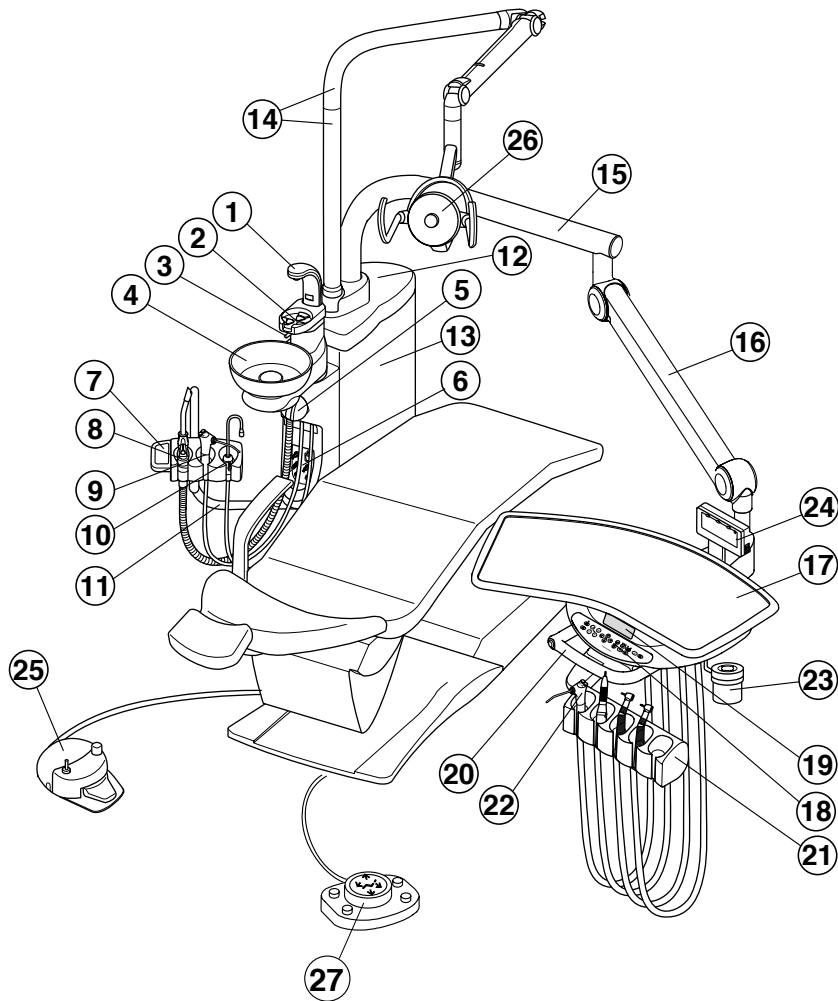

Fig.1-2 Unit Section Overall View

Unit Section Major Components

- | | |
|--|---|
| (1) Cupfiller Nozzle | (14) Light Pole (Light Pole and L-Light Pole) |
| (2) Cupfiller Base | (15) First Arm (Horizontal Arm) |
| (3) Bowl Flush Nozzle | (16) Balance Arm |
| (4) Spittoon Bowl | (17) Instrument Tray |
| (5) Solid Collector | (18) Main Control Panel |
| (6) Cuspidor Unit Control Panel | (19) Dr. Table Indicator (for E spec.) |
| (7) Assistant Holder
(With Membrane Switch) | (20) Tray Handle (With Arm Air Brake Button) |
| (8) Vacuum Handpiece | (21) Dr. Side Handpiece Holder |
| (9) Assistant Side Syringe | (22) Dr. Side Syringe |
| (10) Saliva Ejector Handpiece | (23) Waste Receptacle |
| (11) Assistant Holder Arm | (24) Film Viewer |
| (12) Cuspidor Top | (25) Foot Controller |
| (13) Cuspidor Body | (26) Dental Light |
| | (27) Chair foot Control |

2. DIMENSIONS AND SPECIFICATIONS

2-1. CHAIR SECTION DIMENSIONS

-mm-

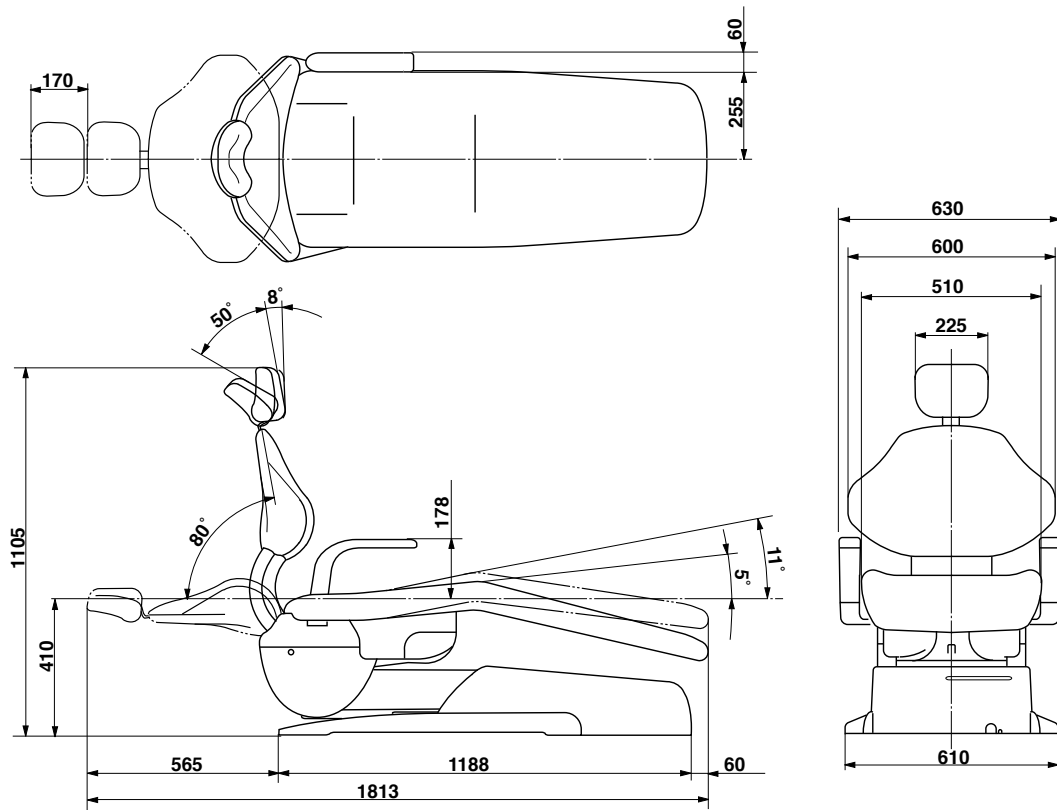

Fig.2-1 Chair Dimensions

2-2. CHAIR SECTION SPECIFICATIONS

Seat Initial Height-----	410mm
Seat Lifting Stroke-----	380mm
Backrest Movement -----	0° ~ 80° above Horizontal
Tilting Mechanism-----	Backrest Synchronized Tilting (5° ~ 11° above Horizontal)
Auto Movements-----	2-Preset, Last Position Memory and Auto Return
Control Voltage-----	DC12V
Power Consumption -----	115V, 50/60Hz, 500/490W 220/230V, 50/60Hz, 510/530W 240V, 50/60Hz, 650/680W
Net Weight -----	115 kg

2-3. UNIT SECTION DIMENSIONS

-mm-

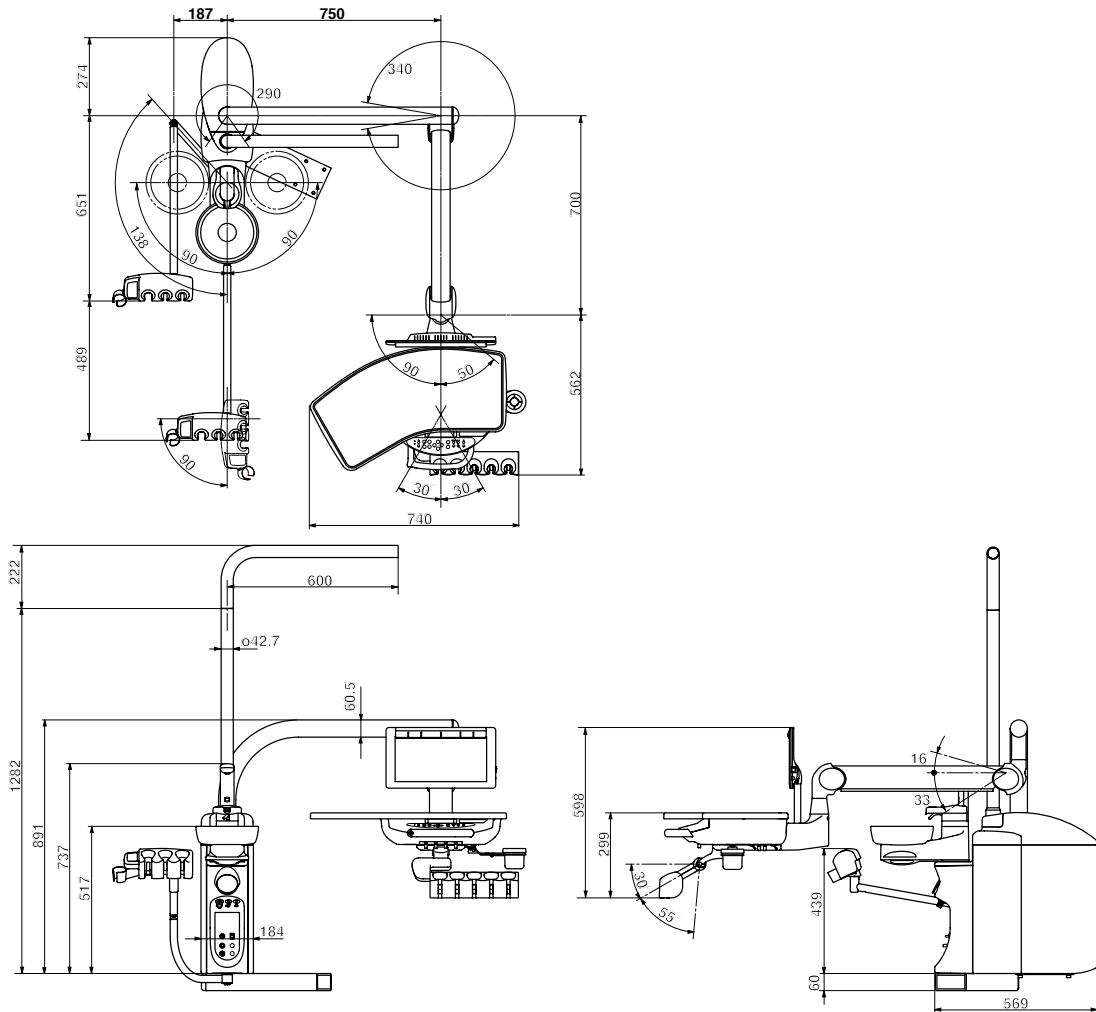

Fig.2-2 Unit Section Dimensions

2-4. UNIT SECTION SPECIFICATIONS

Doctor Side Instrument-----	2 x High Speed Turbine Tubings
	1 x Low Speed Air Motor Tubing
	1 x 3 Way Syringe
Assistant Side Instrument-----	Saliva Ejector (Central Vacuum Type)
	Vacuum (Central Vacuum Type)
	1 x 3 Way Syringe
Bowl Flush-----	Timer Mode and Continuous Mode
Cupfiller -----	Timer
Net Weight -----	94.7 kg (Without Dental Light)

3. REQUIREMENTS FOR INSTALLATIONS

A. General Requirements

- (1) The contractor is to supply the necessary service and materials to complete the installation to the satisfaction of the dentists and the installation engineer.
- (2) This includes the supply and installation of the electric power supply cables with main isolating switch and fuses, air supply piping, water supply piping, suction piping including vacuum pump and its control wires and drain piping as noted on the installation diagrams.

B. Setting Requirements

- (1) The CLESTA II dental unit comprises of a Chair section, Cuspidor section, Doctor table section and Light section.
- (2) The CLESTA II should be mounted taking the opening end of drain pipe into due consideration. Refer to Page 7, Fig.3-1.
- (3) The area on which the CLESTA II (250 kg) is to be installed must have endurance force of 250kg/m².
- (4) The installation position of the CLESTA II chair is shown in Fig.3-1 as a recommended example.

C. Piping and Plumbing Requirements

- (1) All piping and conduit for cables are to be laid under the floor and to come out from the floor in the positions shown Fig 3-1
- (2) The installation position and height from the floor of each pipe and cable conduit are shown in Fig.3-1.
- (3) The recommended sizes, materials and end piece are shown in Table 1.
- (4) Regarding installation of the vacuum pump and its connection to the main suction line, follow the specifications of central vacuum pump system manufacture's recommendation.
- (5) All Piping should be arranged avoiding bends as much as possible.

Table 1 The Recommended Sizes, Materials and End Piece of Pipes

Item	Material	Size	End Piece
Compressed Air Supply Pipe	Shock Resistance P.V.C. Pipe HI-13	Out. Dia.18mm In. Dia. 13mm	PT1/2
Water Supply Pipe	Shock Resistance P.V.C. Pipe HI-13	Out. Dia. 18mm In. Dia. 13mm	PT1/2
Suction Pipe	P.V.C. Pipe VP-20	Out Dia. 26mm IN. Dia. 20mm	
Drain Pipe	P.V.C. Pipe VP-50	Out. Dia. 58mm In. Dia. 50mm	
Power Supply Cable Conduit	P.V.C. VE-16	In. Dia. 16mm	
Vacuum Control Wire Conduit	P.V.C. VE-16	In. Dia. 16mm	

Note : The suction pipe and drain pipe should be laid under the floor with an inclination of 1/200 - 1/400.
Air vacuum type does not require suction pipe, vacuum control wire and its conduit.

D. Air Supply Requirements

- (1) Compressed air to be supplied should be filtered.

Dirt and moisture in the air may cause trouble in unit air system.

- (2) Air Pressure

Regulate the outlet air pressure of the compressor to the utility section at 0.55-0.6MPa (5.5 - 6.0kg/cm²) and the air pressure should be kept higher than 0.5MPa (5.0kg/ cm²) at any time.

- (3) Compressed Air Supply Capacity

Compressed air supply capacity is at least 55 l/min. (Central Vacuum type)

Compressed air supply capacity is at least 88 l/min. (Air vacuum type)

E. Water Supply Requirements

- (1) The supply water should be clean.

Dirty water may cause trouble in unit water line.

- (2) Water Pressure

More than 0.1MPa(1.0kg/cm²) water pressure in utility section is required for operating unit efficiently at any time.

F. Electric Supply Requirements

- (1) The connection of the power supply cable is to be carried out in accordance with the local electrical regulation.

- (2) Rating of supply voltage and power consumption :

100/110/115V Type Single Phase 50/60 Hz : 15 A

220/230/240V Type Single Phase 50/60 Hz : 10 A

- (3) Power supply line should be provided with fuses or circuit breaker in accordance with power consumption.

- (4) The earth wire (ground wire) should be provided in the utility section.

- (5) All cables should have at least 500mm surplus from the floor so that they are long enough to be connected to the terminals in the utility section.

Standard Type

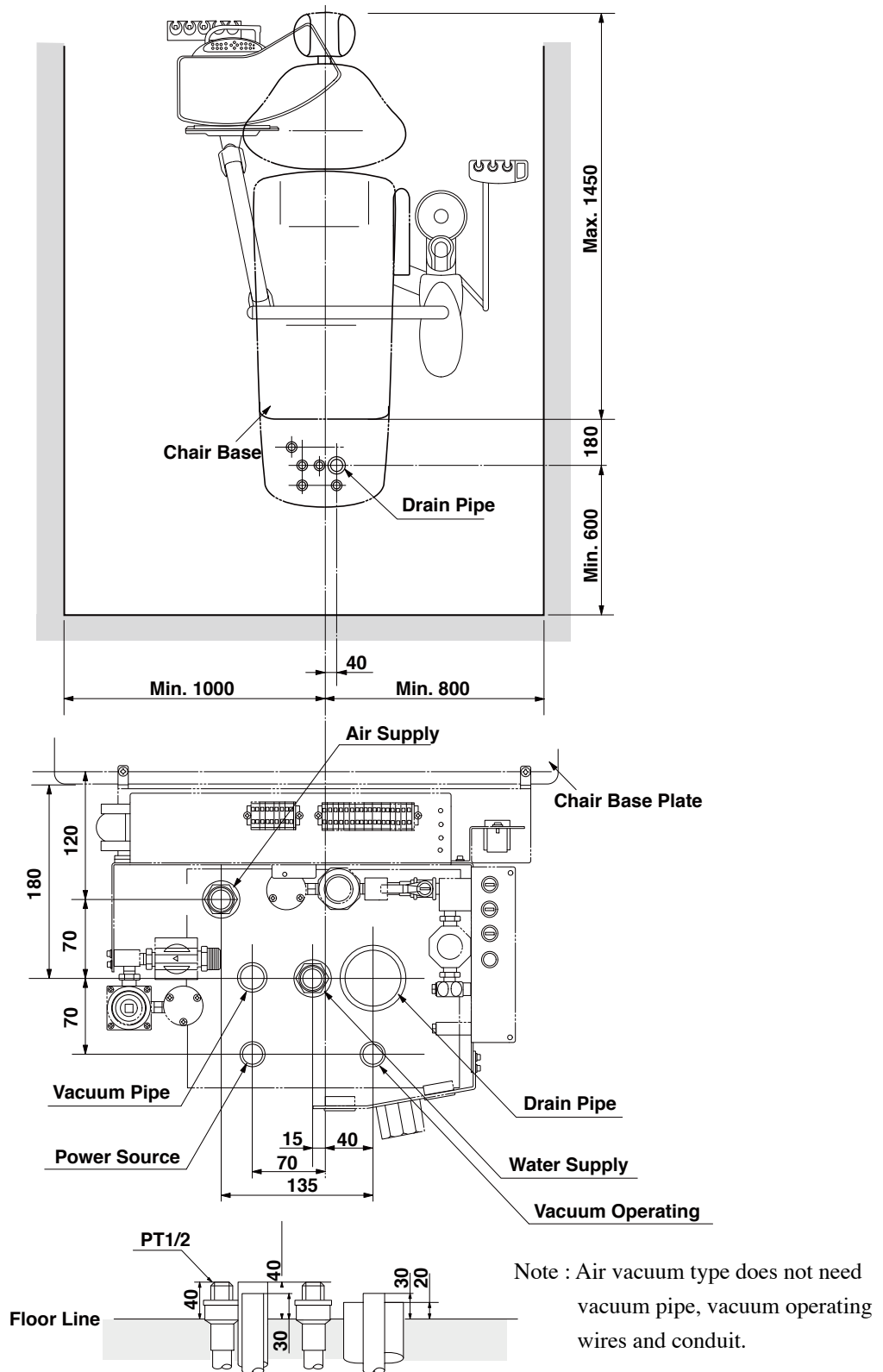

Fig.3-1 Installation Position and Plumbing Layout
(Central Vacuum Type)

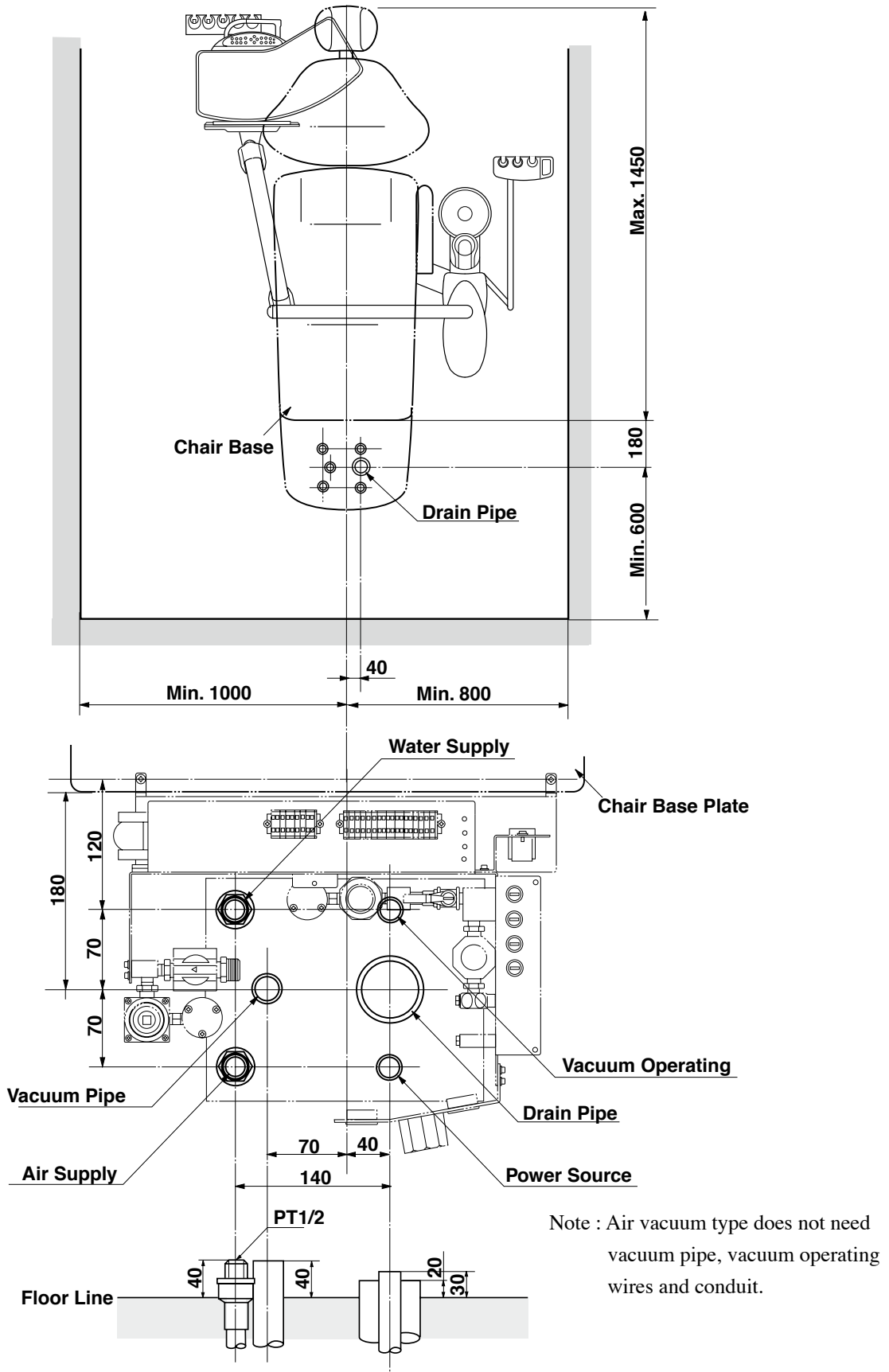

Fig.3-2 Installation Position and Plumbing Layout
(Central Vacuum Type)

4. CHAIR SECTION PREPARATION FOR INSTALLATIONS

4-1. CHAIR SECTION UNPACKING

The chair is delivered in 2 cartons (base section and top section cartons).

Open the upper section carton and check the contents with following check list.

CAUTION

Do not use a sharp instrument, it may damage upholstery.

Check List for Upper Section Carton

- | | |
|--|--------|
| 1. Headrest Assembly ----- | 1 set |
| 2. Backrest Assembly----- | 1 set |
| (Backrest Cushion with Backrest Support Plate, Backrest Cover) | |
| 3. Seat Assembly ----- | 1 set |
| 4. Armrest (Standard Type; Left Side only Right arm optional)----- | 1 set |
| 5. Screw Kit | |
| (1) M6 Wood Screw for Fixing Base (2 x L40, 2 x L55)----- | 4 pcs. |
| (2) M12 x 20 Set Screw for Base Level Adjustment----- | 4 pcs. |
| (3) M10 x 30 Set Screw for Level Adjustment Adapter ----- | 4 pcs. |
| (4) M6 Screw, Flat washer and Armrest Collar for Armrest ----- | 1 set |
| (5) M6 x 20 Screw for Fixing Backrest Cushion and Seat ----- | 6 pcs. |
| (6) M6 Flat Washer for Fixing Seat ----- | 2 pcs. |
| (7) M8 x 20 Cap Bolt with Spring Washer for Back Support Plate----- | 4 pcs. |
| (8) M5 x 12 Screw (White) for Flange Hose Cover and Pump Cover----- | 5 pcs. |
| (9) Hole Plug for Carriage Bar Hole ----- | 2pcs. |
| (10) Nylon Clamp with M5 Screw for Fixing Drain Hose ----- | 1 set |
| (11) M5 x 15 Screw , Set Cap Washer and Set Cap Cover for Pump Cover ----- | 1 set |

4-2. CHAIR SECTION PREPARATIONS FOR INSTALLATIONS

CAUTION

Do not connect the power supply line before removing Red tagged bolt.

- (1) Remove all the staples fixing the carton to the pallet, or cut the carton just above the stapled line, and remove the carton. (Fig.4-1)

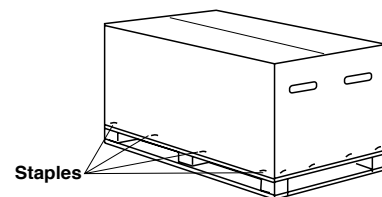

Fig.4-1 Chair Base Section Carton

- (2) Place the base section with pallet behind the planned location for chair.

- (3) Remove the pump cover.

Remove wood screws from the base.

Remove the base section from the pallet by holding the carriage bars (Front side and Rear side) and place it at the planned location.

(Fig.4-2)

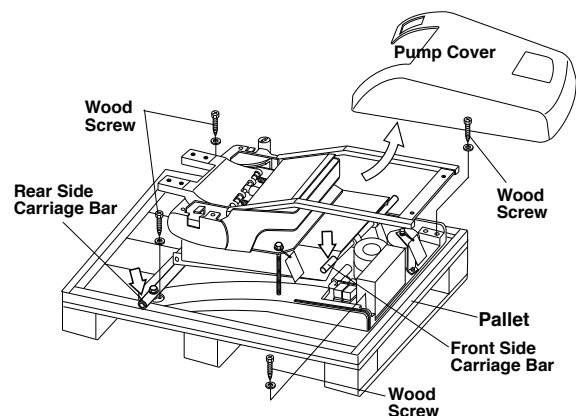

Fig.4-2 Removing Base Section from Pallet

⚠ CAUTION

Do not lift the chair by upper structure after removing the carriage bolt (Red tagged bolt).

- (4) Remove the rear side carriage bar from the base. (Fig.4-3)

Note : The front side carriage bars can not remove. They are covered by the pump cover.

- (5) Remove the carriage bolt (Red tagged bolt) from the support plate. (Fig.4-3)

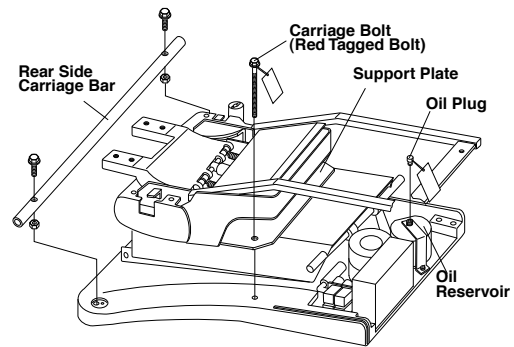

Fig.4-3 Removing Red Tagged Bolt

- (6) Remove the red tagged oil plug from the oil reservoir. (Fig.4-3)

- (7) After removing the carriage bolt, plug the power supply cable into suitable power supply outlet. Lift up the upper structure by the foot switch to the highest position. Raise the backrest support by the foot switch to the upright position. (Fig.4-4)

Note : Refer to the operating manual for chair operation.

- (8) Remove 2x M5 screw from either side of the main link cover and remove the main link cover. (Fig.4-4)
- (9) Remove the set cap covers from either side of the lower flange cover. Remove 4 x M5 screws and remove the lower flange cover. (Fig.4-4)

- (10) Lift up the seat frame to the back support side. (Fig.4-4)

Note : Do not remove the support plate until the cuspidor unit has been mounted onto the chair.

⚠ CAUTION

After raising the chair base, disconnect the power supply to the chair.

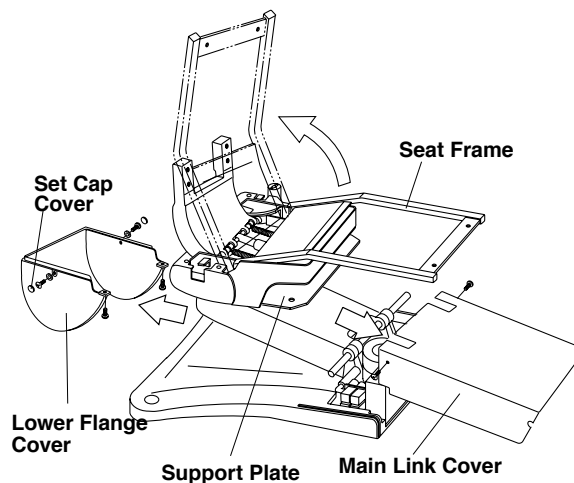

Fig.4-4 Chair Preparations for Installations

5. UNIT SECTION PREPARATIONS FOR INSTALLATIONS

5-1. UNIT SECTION UNPACKING

Checking Contents

The standard type Clesta-2 unit is delivered in 1 carton.

Installation parts and accessory parts are packing in the small carton boxes.

Open the parts boxes and check the contents of each packing with following the check list.

CAUTION

Do not use a sharp instrument to open the packing, it may damage the parts.

Check List

1. Cuspidor Unit with Doctor Table and Utility section ----- 1 set
2. L-Light Pole and Light Pole (2xM6 Cap Bolt with S/Washer) ----- 1 set
3. Dr. Table Tray (4xM5 Screw) ----- 1 set
4. Parts Boxes
 - (1) Drain Cap and Basket Strainer ----- 1 piece
 - (2) Cuspidor Bowl ----- 1 piece
 - (3) Vacuum Tip (Straight and Bent) ----- 1 set
 - (4) Vacuum Silicon Tip ----- 10 pieces
 - (5) Vacuum Elbow ----- 1 piece
 - (6) Drain Elbow ----- 1 piece
 - (7) Stop Valve with Seal (Water & Air) ----- 2 set
 - (8) Stainless Flexible Pipe with 2-Seals ----- 2 set
 - (9) Waste Receptacle ----- 1 set
 - (10) Cotton Container with Base ----- 1 set
 - (11) Vials (5 Colour Vials) with Base ----- 1 set
 - (12) Vacuum Hose with Handpiece ----- 1 set
 - (13) Saliva Ejector Hose with Handpiece ----- 1 set
 - (14) Foot Controller ----- 1 set
 - (15) Cap Bolt for Fixing Cuspidor Unit ----- 4 sets
(M10 Cap bolt (L=40 & L=60) with Spring Washer)
 - (16) Dental Size Film Viewer ----- 1 set

Note : The check list is for the standard type.

5-2.UNIT SECTION PREPARATIONS FOR INSTALLATIONS

- (1) Remove all wood screws fixing the carton to the pallet and lift up to remove the carton.
(Fig.5-1)

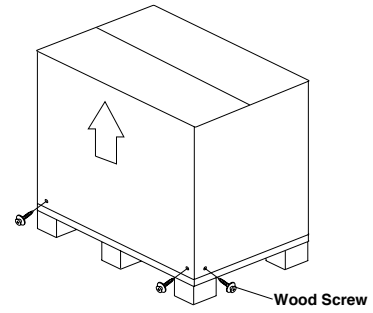

Fig.5-1 Unit Section Carton

- (2) Place the unit with pallet behind the planned location.

- (3) Remove a unit fixing bolt (M10 - 25) and hold the unit..

- (4) Remove four bolts (M8-35) and two fixing brackets.(Fig.5-2)

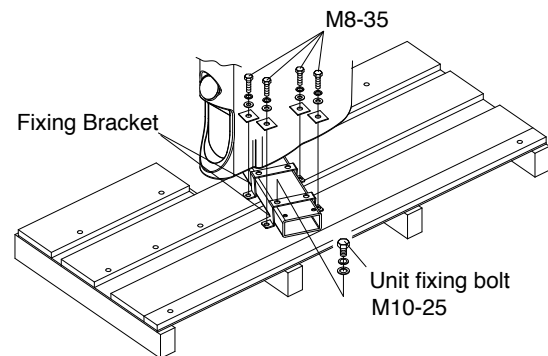

Fig.5-2 Removing Unit from Pallet

Note : Do not remove the unit from the pallet until the chair is ready and in the correct position.
Refer to 4-2.

6. INSTALLATIONS INSTRUCTIONS

6-1.MOUNTING THE CUSPIDOR UNIT ON TO THE CHAIR

(1) The Cuspidor Unit Mounting Position onto the Chair

The cuspidor unit mounting position on the chair is shown in Fig.6-1.

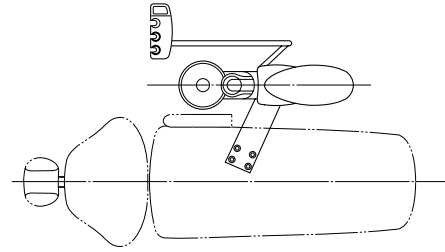

Fig.6-1 Unit Mounting Position on the Chair

(2) Mounting The Cuspidor Unit

- A. Hold the cuspidor unit while on the pallet and remove 3 x M10 bolts from under the mounting adapter. (Fig.5-2)

CAUTION

Carry the unit by holding the cuspidor at the bottom and mounting adapter.

Do not carry by holding the arm, cupfiller nozzle or cuspidor bowl.

When mounting the cuspidor unit onto the chair, keep the assistant arm to the out side of the chair.

- B. Lift up the unit from the pallet and position the assistant arm to the out side of the chair and remove the pallet from this area. Put the mounting adapter on to the support plate. Adjust the adaptor position to line up the adapter plate screw holes to the flange screw holes and fit it with 4xM10 cap bolts. (Fig. 6-2)

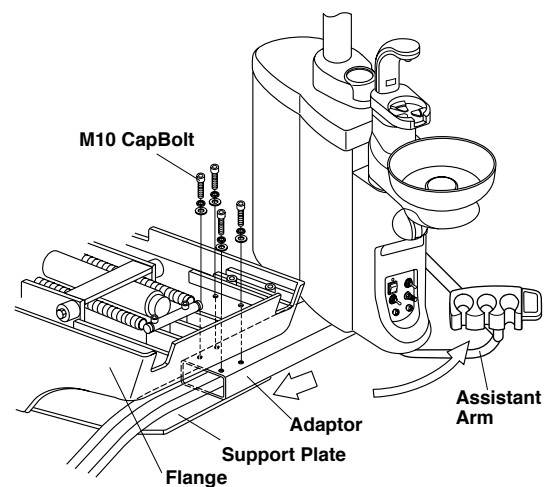

Fig.6-2 Mounting the Cuspidor Unit onto the Chair

Note : M10 cap bolts are packed in the unit parts box.

- C. After mounting the unit onto the chair fit the 4 x M10 set screws (Level adjuster screws) into the flange. Use these set screws (M10) to adjust the level of the unit. (Fig. 6-3)

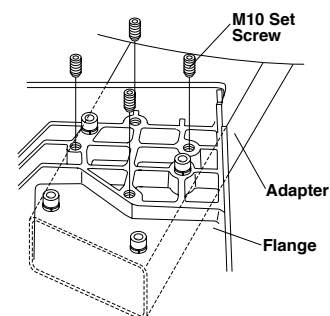

Fig.6-3 Setting Level Adjuster Screws

- D. Remove 3 x M8 cap bolts and remove the black support plate from under the flange. (Fig.6-4)

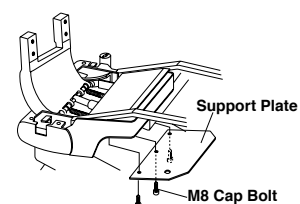
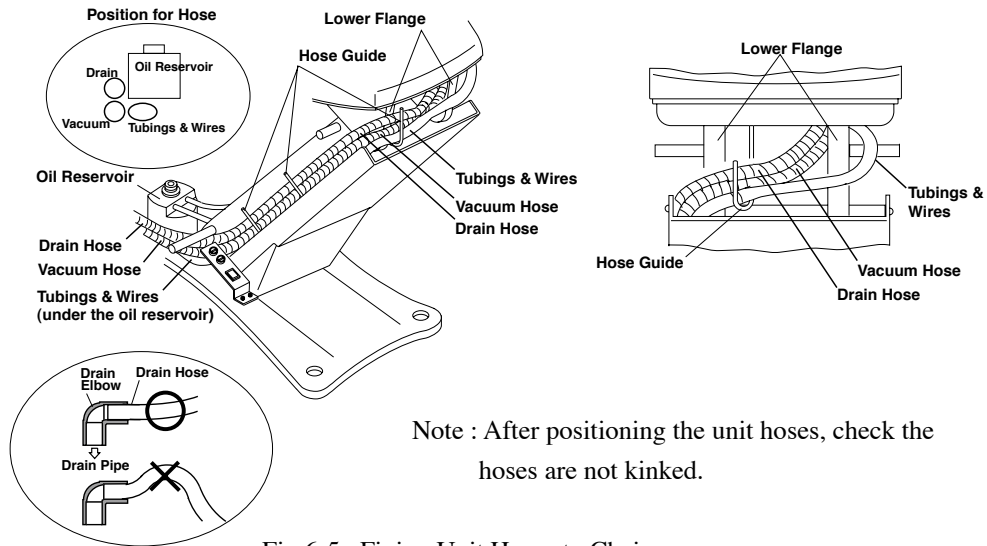

Fig.6-4 Removing Support Plate

6-2. FIXING THE UNIT HOSES TO CHAIR

(1) Fixing The Unit Hoses to Chair (Fig.6-5)

- A. Pass through the vacuum hose and drain hose between the lower flange and fix them in the hose guides.
- B. Pass the unit tubing and wires around the right side lower flange and fix them in the hose guides.
- C. Fit the vacuum hose, drain hose, tubings & wires to the outer side of the oil reservoir.



Note : After positioning the unit hoses, check the hoses are not kinked.

Fig.6-5 Fixing Unit Hoses to Chair

6-3. INSTALLATIONS OF UTILITY SECTION

(1) Stop Valves Installations

- A. Place the chair in the planned location. Confirm that the piping and wirings are laid out in accordance with Fig.3-1.
- B. Install the water stop valve and the air stop valve to each supply pipe.

The positioning of the stop valves are shown in Fig.6-6.

- C. After installation of the stop valves, fully open the valves and flush out dust and chips from the piping.

Note :During installation, close the stop valves.

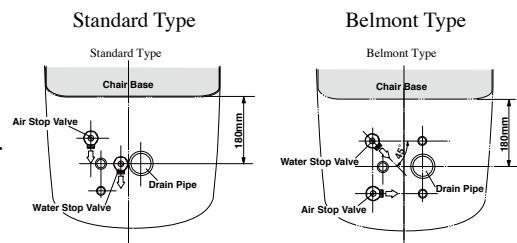

Fig.6-6 Direction of Water and Air Stop Valves

(2) Utility Section Frame Installations

- A. Remove 4 x M4 screws and remove the pressure gauge bracket from the utility section frame to make installation space. (Fig.6-7)
- B. Position the utility section frame onto the chair base plate.
- C. Fix the utility section frame to the chair base with 2 x M5 screws. (Fig.6-7)
- D. Fix the foot controller hose to the chair base with clamp. Recommended length of foot controller hose is 800mm from the clamp.

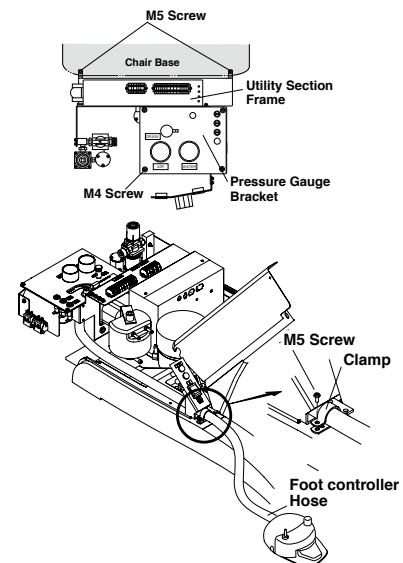

Fig.6-7 Utility Section Frame Installation

(3) Drain Hose and Vacuum Hose Connection

- A. Run the drain hose and vacuum hose through and under utility section frame. (Fig.6-8)
- B. Cut the drain hose and vacuum hoses at suitable length and connect them to each elbow with plastic glue.(Pipe solvent)
- C. Insert the drain hose elbow and vacuum hose elbow into each pipe. (Fig.6-8)

Note : The Drain pipe should be sealed with silicone sealant or taping.

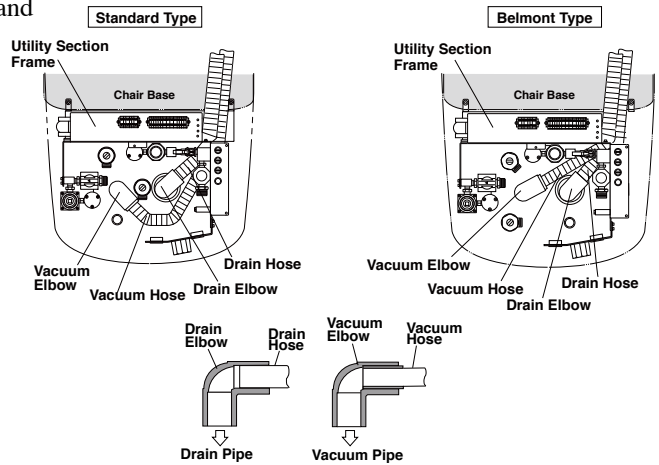

Fig.6-8 Drain Hose and Vacuum Hose Connection

(4) Water and Air Supply Line Connection

- A. Bend each stainless flexible pipe to a suitable angle for connection.
- B. Connect the water supply line to the water stop valve with the stainless flexible pipe and the seals. (Fig.6-9)

Note : Pass through and connect the water stainless flexible pipe to the water stop valve under the vacuum elbow

- C. Connect the air supply line to the air stop valve with the stainless flexible pipe and the seals. (Fig.6-9)

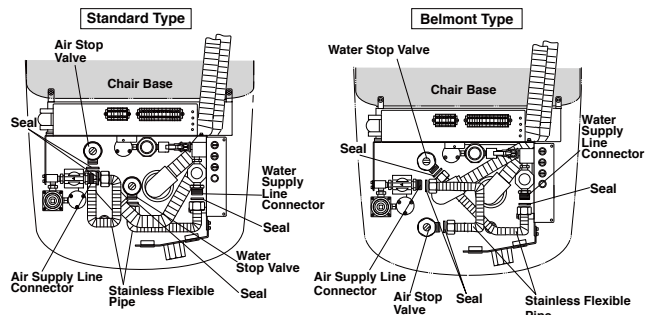

Fig.6-9 Water and Air Supply Line Connection

(5) Electrical Connections in The Utility Section

- A. Chair Control Connector (4P) (Fig.6-10A)

Connect the unit side connectors (4P Female) to the chair side connectors (4P Male) in the utility section.

- B. Chair Power Supply (Fig.6-10A / Fig.6-10B)

Connect the chair power supply cable to terminal No.5 and No.6.

Connect the earth wire in the power supply cable onto the utility section frame with M4 screw.

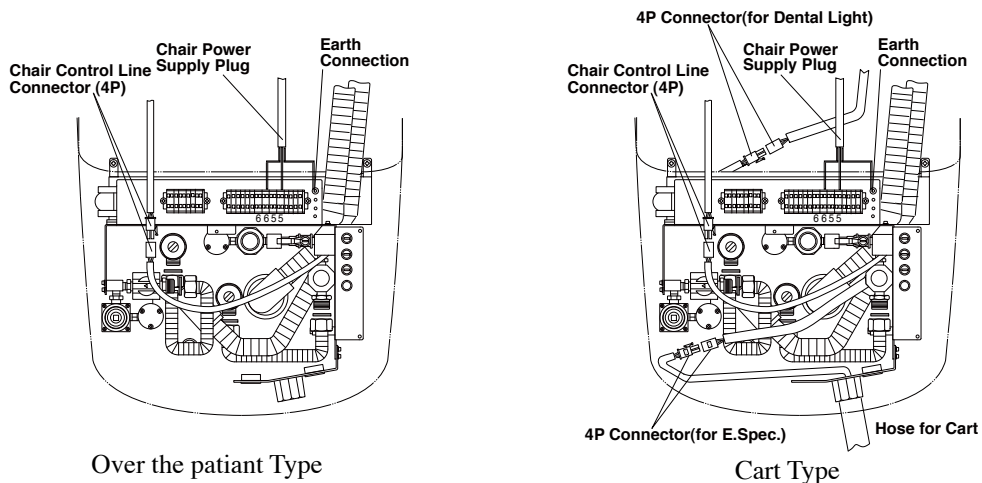

Fig.6-10A Wires Connection-A

- C. Vacuum Operating Wires (Central Vacuum)
 Connect the central vacuum operating wires to terminal No.1 and No. 2. (Yellow wires are connecting.) (Fig.6-10B)

Note : How to connect terminal block
 (Fig.6-10B)

While pressing the slot of the terminal with a small thin screw driver, insert the wire to the terminal and release the screw driver.
 Confirm that the wire is connected securely.

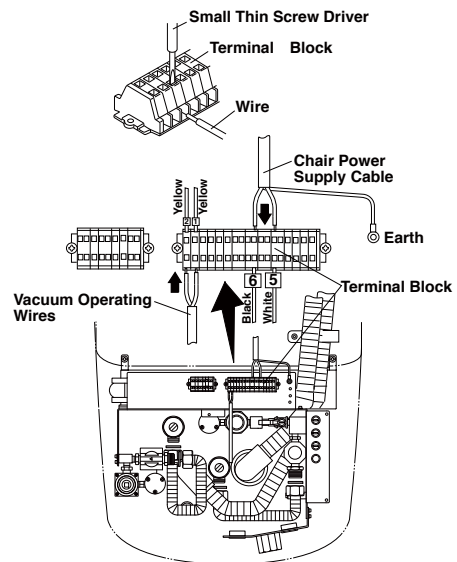

Fig.6-10B Wires Connection-B

- D. Unit Power Supply Line
 Fix the plug on the end of the unit power supply cable. Plug the unit power supply plug into the suitable power supply line in the utility section. (Fig.6-10C)

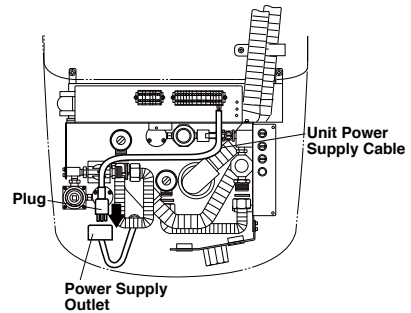

Fig.6-10C Wire Connection-C

- E. Tubings connection for Cart Type
 Refer to Fig.6-10D
 Connect the tubings from the cuspidor unit to utility parts.

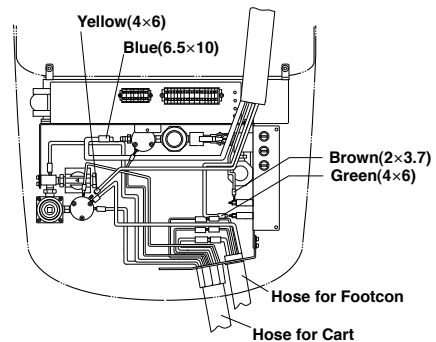

Fig.6-10D Tubing Connection for Cart

- (6) Fixing the Pressure Gauge Bracket
 Fix the pressure gauge bracket onto the utility section frame with 4 x M4 screws.
 Open the main water valve. (Fig.6-10E)

Note : After connecting the utility section, open the stop valves and turn on the main switch to check the unit and chair.

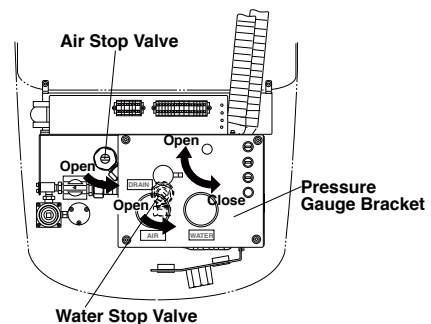

Fig.6-10E Fixing the Pressure Gauge Bracket

6-4. INSTALLATION OF THE DENTAL LIGHT
(CHAIR MOUNT TYPE)

(1) Installing The Dental Light

A Remove the 4 x side panel fixing screws from the bottom of the cuspidor unit and remove the side cover. (Fig.6-12)

B. Pass the light wires through the L-light pole and insert the light spigot into the light pole and fix it with 2 x M6 screws. (Fig.6-11)

C. Remove the light pole cover from the cuspidor unit. Insert the light pole into the light pole cover. (Fig.6-12)

D. Pass the light wires through the light pole and insert the L-light pole into the light pole. Insert the light pole with dental light and L-light pole into top of the cuspidor unit. (Fig.6-12)

E. Fix the light pole in to the cuspidor unit and tightening the 2x M6 cap bolts. Fix the light pole cover to the cuspidor unit. (Fig.6-12)

F. a) Dental Light 720S (Fig.6-13)

Pass the light wires through the cuspidor frame. Connect 6P and 2P connectors of the dental light cable to the dental light PCB. The dental light PCB is located at the rear side of the cuspidor unit.

b) Dental Light IO5000 (Fig.6-13)

Pass the light wires through the cuspidor frame and insert light cable pins into each connector in the cuspidor unit. Wire colours and connectors for connection are shown in Fig.6-13. The dental light PCB is located at the rear side of the cuspidor unit.

G. After fitting the dental light onto the cuspidor unit, tighten 4 x M5 set screws on the light spigot firmly, after adjusting the counter sunk screw to the required tension. (Fig.6-14)

H. After installing the dental light, fix the side panel back onto the cuspidor. (Fig.6-12)

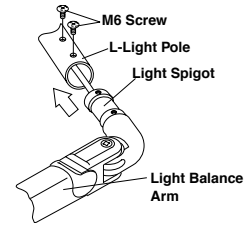

Fig.6-11 Fixing the Dental Light to L-Light Pole

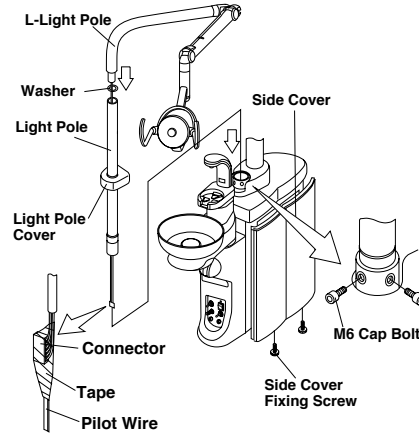
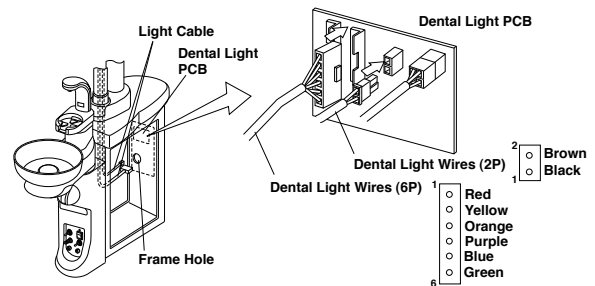

Fig.6-12 Fixing Light Pole to Cuspidor Unit

a. Dental Light 720S



b. Dental Light IO5000

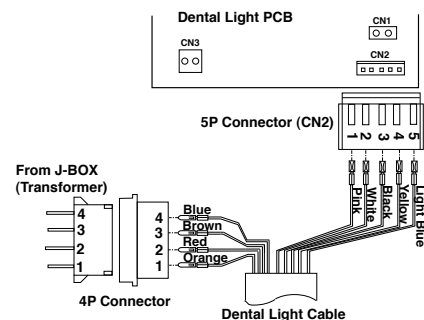

Fig.6-13 Connecting the Dental Light Connectors

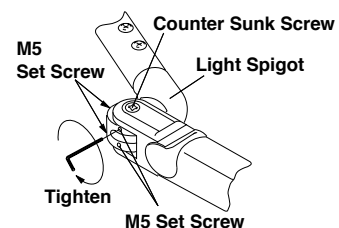

Fig.6-14 Tightening the Set Screws on the Light Spigot

6-5. CHAIR SECTION ASSEMBLY

(1) Fixing the Covers

CAUTION

Do not pinch the tubing with the cover.

- A. Return the seat frame to the original position. (Fig.6-15)
- B. Fix the main link cover. (Fig.6-15)
- C. Fix the lower flange cover and fix the cap covers on the screw heads. (Fig.6-15)

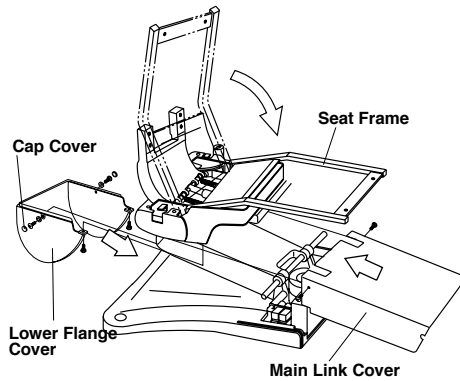

Fig.6-15 Fixing Main Link Cover and Lower Flange Cover

- D. Fix the flange hose cover with 3 x M5 truss screws. (Fig.6-16)

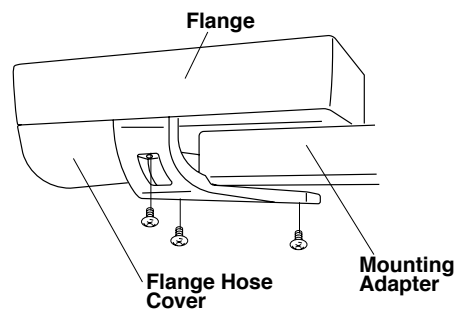

Fig.6-16 Fixing Flange Hose Cover

(2) Fixing the Backrest

- A. Fix the back support plate to the back support by 4 x M8 cap bolts and spring washers. (Fig.6-17)

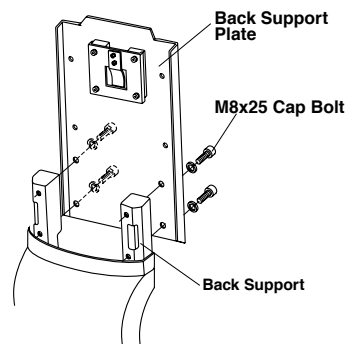

Fig.6-17 Fixing Back Support Plate

- B. Fix the backrest cushion to the back support plate by 4 x M5 screws. (Fig.6-18)

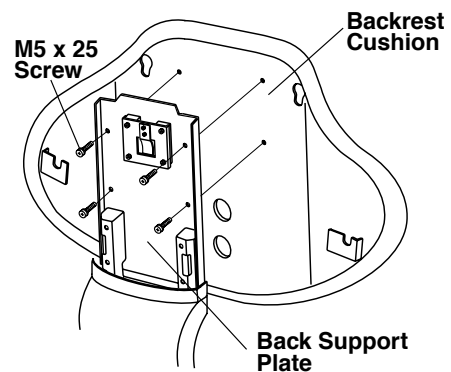

Fig.6-18 Fixing Backrest Cushion

C. Attach the backrest cover to the backrest cushion.

Insert upper two hooks of backrest cover into the upper fixing holes of the backrest. Keep pressing the backrest against backrest, slide down the backrest cover so that lower two hooks catch the lower fixing holes. (Fig.6-19)

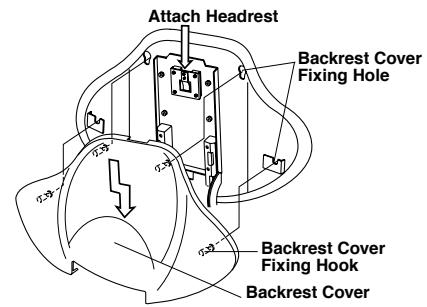

Fig.6-19 Fixing Backrest Cover and Headrest

D. Attach the headrest. (Fig.6-19)

E. Fix the seat to the base section.

Hook the seat hooks to the seat fixing plate on the chair base and screw the seat to the seat frame with 2 x M6 screws and flat washers. (Fig.6-20)

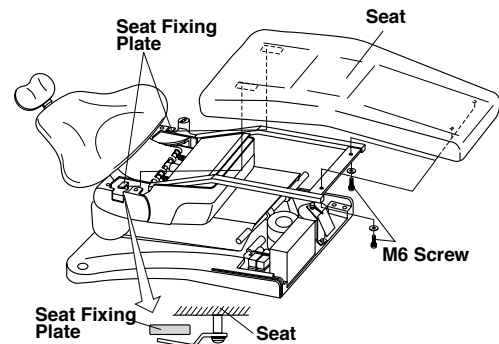

Fig.6-20 Fixing Seat

F. Fix the armrest to the armrest bracket with M6 screw, flat washer and collar. (Fig.6-21)

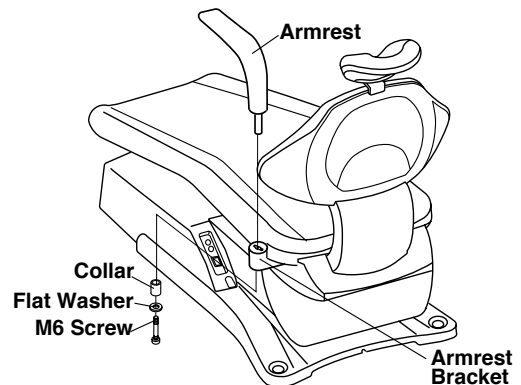

Fig.6-21 Fixing Armrest

(2) Fixing the Base to the Floor

A. After checking the chair position, fix the base on the floor with 4 x wood screws. (Fig.6-22)

B. Fit 4 x M12 set screws (Level adjuster screws) in to the base plate. The chair level can be adjusted with the leveling screws. (Fig.6-22)

C. Fix the hole plugs in the carriage bar holes on the base. (Fig.6-22).

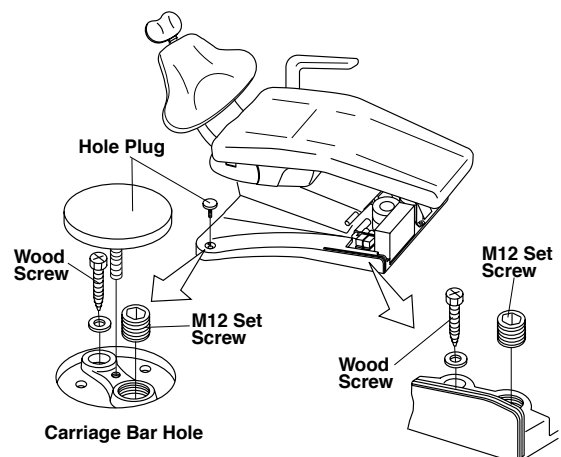

Fig.6-22 Fixing Base on Floor

6-6. UNIT SECTION ASSEMBLY

(1) Doctor's Syringe and Handpiece Tubings.

Fit the syringe and the handpiece tubings into each handpiece holder. Position the handpiece to each handpiece tubing.

(2) Vacuum Hose and Saliva Ejector Hose

Fix the vacuum hose and saliva ejector hose to the vacuum manifold by turning the hose connector 90° clockwise.

(Fig.6-23)

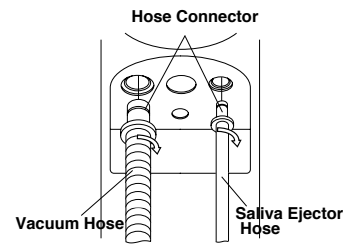

Fig.6-23

Fixing Vacuum and Saliva Ejector Hose

(3) Assistant's Syringe, Vacuum and Saliva Ejector Handpiece

Fit the syringe, the vacuum handpiece and the saliva ejector handpiece in the assistant holder.

(4) Cuspidor Bowl, Drain Cap and Basket Strainer (Fig.6-24)

Insert the cuspidor bowl into the cuspidor unit.

Fit the drain cap and the basket strainer in the centre of cuspidor bowl.

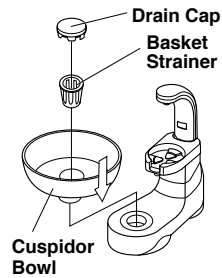

Fig.6-24 Cuspidor Bowl

(5) Film Viewer for Holder and Place Type

Fix the film viewer on the table bracket with 2 x M4 screws.

(Fig.6-25)

(6) Table Tray for Holder and Place Type

Fix the table tray on the table with 4 x M5-10 screws

and 1 x M5- 60 screw. (Fig.6-25)

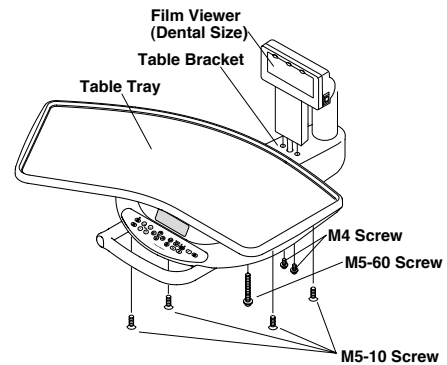

Fig.6-25 Fixing Film Viewer and Table Tray

(7) Rod and Rest Cover for Rod Type (Fig.6-26)

Lift the rod holder and insert the rod to the rod holder.

Attach the rest cover to the table cover.

(8) Fixing Pump Cover

Before fixing the covers, check all unit and chair functions are working correctly.

After fixing the covers, check again.

⚠ CAUTION

Do not pinch or damage the tubing and wire with the covers.

Do not bend the tubing excessively with the covers (prevent kinking tubings.)

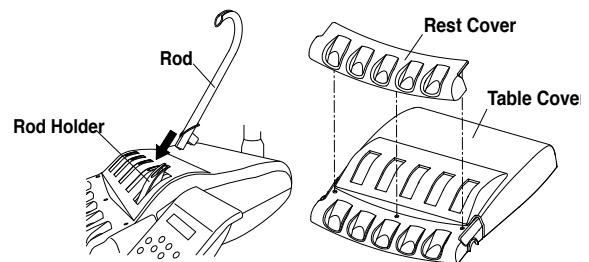

Fig.6-26 Rod and Rest Cover

Pump Cover (Utility Section Cover)(Fig.6-27)

Fix the chair pump cover with 3 x M5 screws and fit the maintenance lid.

The front side of the pump cover is fixed M5 screw with set cap washer and set cap cover.

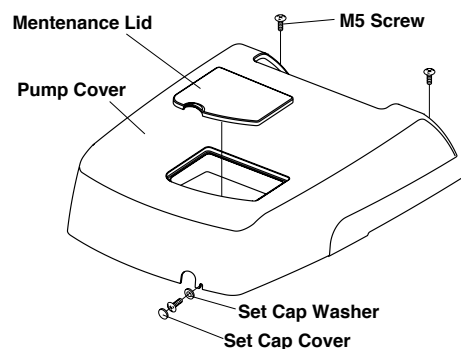

Fig.6-27 Pump Cover and Maintenance Lid

7. ADJUSTMENT

7-1. UNIT SECTION ADJUSTMENT

(1) Water and Air Stop Valves (Fig.7-1)

Open the water stop valve and the air stop valve in the utility section.

Turn on the master switch and check that water and air are not leaking.

(2) Main Air Pressure (Fig.7-1)

The main air pressure has been adjusted in the factory.

Confirm that the main air pressure is at 0.5-0.55Mpa (5.0 - 5.5 kg/cm²) by the main air pressure gauge.

The main air pressure can be regulated by the main air regulator in the utility section.

(3) Main Water Pressure (Fig.7-1)

The main water pressure has been adjusted in the factory.

Confirm the main water pressure is at 0.1-0.2Mpa (1.0-2.0 kg/cm²) by the main water pressure gauge.

The main water pressure can be regulated by the main water regulator in the utility section.

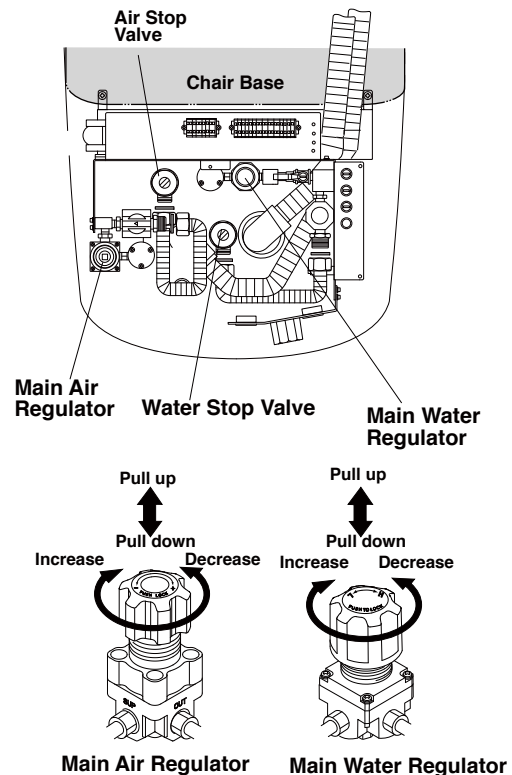

Fig.7-1 Main Air and Main Water Pressure Adjustment

7-2. HANDPIECE ADJUSTMENT

(1) Removing Doctor Table Top (Fig.6-25)

Loosen and remove 4 x M5 screws from the doctor table bottom and remove the doctor table top.

(2) Handpiece Drive Air Adjustment

Adjustment of each handpiece drive air can be made by the screw on the auto select valve.

It is important to set the drive air pressure in according with the handpiece manufacture's recommendation.

Drive air pressure is indicated on the handpiece pressure gauge located on the rear side of table.

(Fig.7-2)

(3) Setting The Optimum Condition

Turn the appropriate drive air screw fully clockwise, then depress the drive air pedal on the foot control fully (maximum foot pressure) and turn the screw counterclockwise slowly. Stop turning the screw immediately when the handpiece pressure gauge shows the desired drive air pressure. (Fig.7-2)

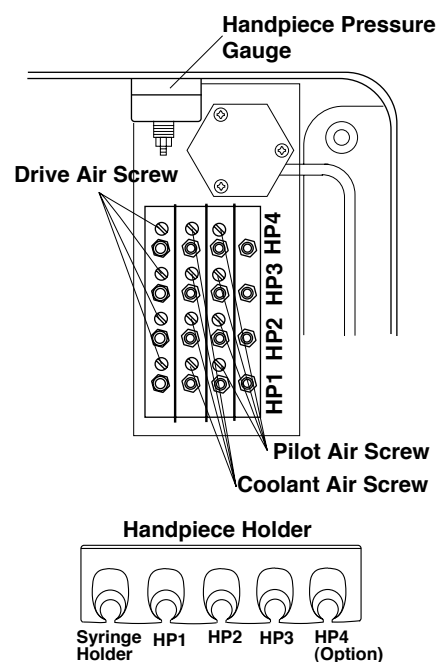

Fig.7-2 Auto Select Valve

(4) Handpiece Coolant Air Adjustment

Handpiece coolant air adjustment screws are provided for individual adjustment of handpiece coolant air. Turning a handpiece coolant air adjustment screw counterclockwise increases flow volume and turning clockwise decreases. (Fig.7-2)

Note : Do not touch the pilot air adjustment screws. - This has been factory set.

Do not loosen the adjustment screw excessively, it will make air leaking.

7-3. HANDPIECE HOLDER ADJUSTMENT

(1) Angle and Height Adjustment

- A. Remove the holder support arm cover and loosen the adjustment screw with a hex L wrench. (Remove the plug located on the underside of the holder support arm with a fingernail. The cover can be detached by removing the screw.)
- B. Set the holder at the client's favorite position and fix by tightening the screw. Be careful not to tighten the screw too much.

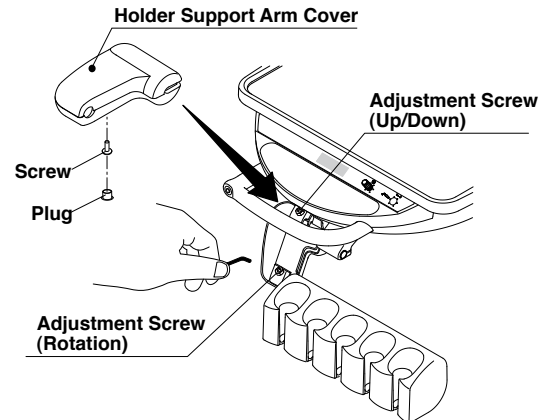

7-4. CHAIR SECTION ADJUSTMENT (Fig.7-3 and Fig.7-4)

(1) Speed Adjustment

Seat lowering speed and backrest reclining speed can be adjusted by the speed control knob on the solenoid valve block. The solenoid valve numbers and functions are shown in Fig.7-3.

- A. Remove the pump cover.
The solenoid valve block is located on the left side at the front of the chair base.
Each speed control knob is located on the rear side of the solenoid valve block.
- B. Loosen the lock nut for the speed control knob.
- C. Turning the speed control knob clockwise to decrease the speed and turning counterclockwise to increases the speed.
- D. After adjustment, tighten the lock nut and reattach the pump cover.

⚠ CAUTION

The chair movement will be locked if the speed is reduced excessively.
Oil may leak from the speed control knob if the speed is increased excessively.

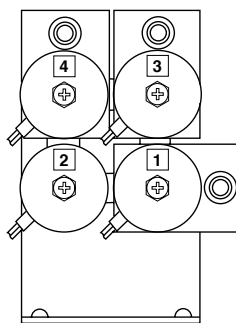

Solenoid Valve Functions

SV1 : Seat Lifting

SV2 : Backrest Raising

SV3 : Seat Lowering

SV4 : Backrest Reclining

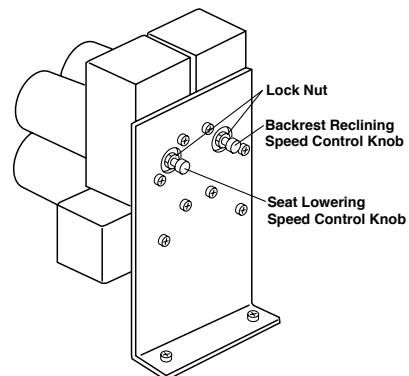
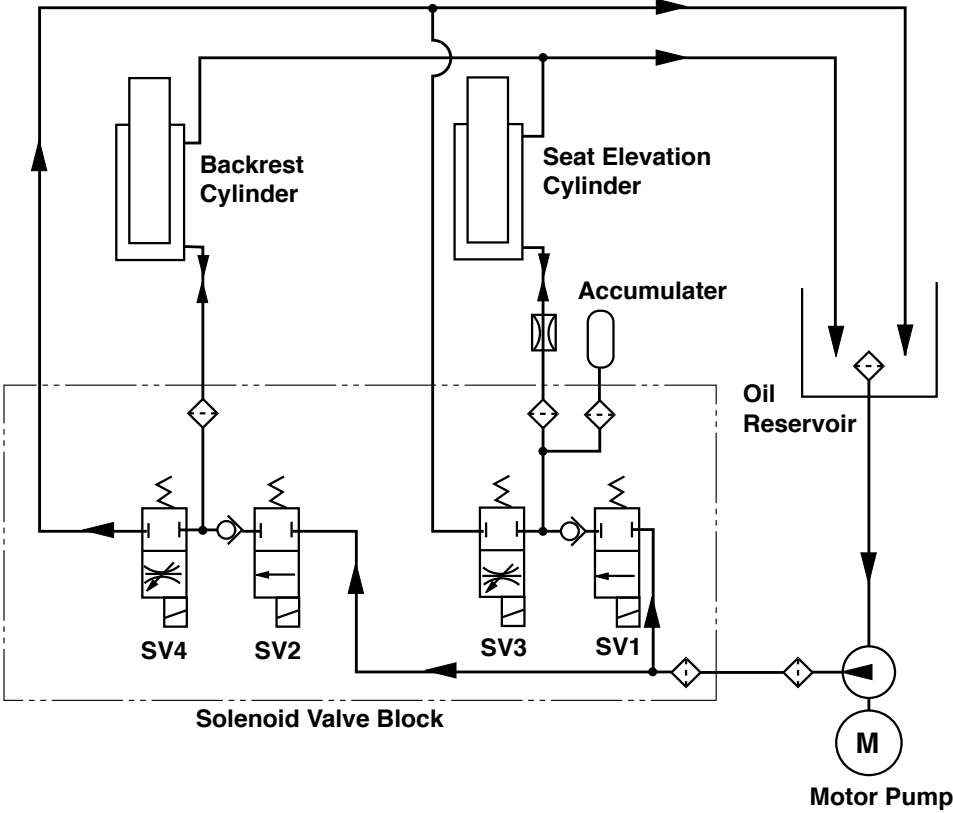

Fig.7-4 Speed Control Knobs on Solenoid Valve Block

Fig.7-3 Solenoid Valve Numbers and Functions

8. CHAIR HYDRAULIC DIAGRAM



- ◊ : Filter
- : Check Valve
- ⊞ : Flow Adjustable Solenoid Valve
- ⊞ : Solenoid Valve

9. CHAIR ELECTRICAL DIAGRAM

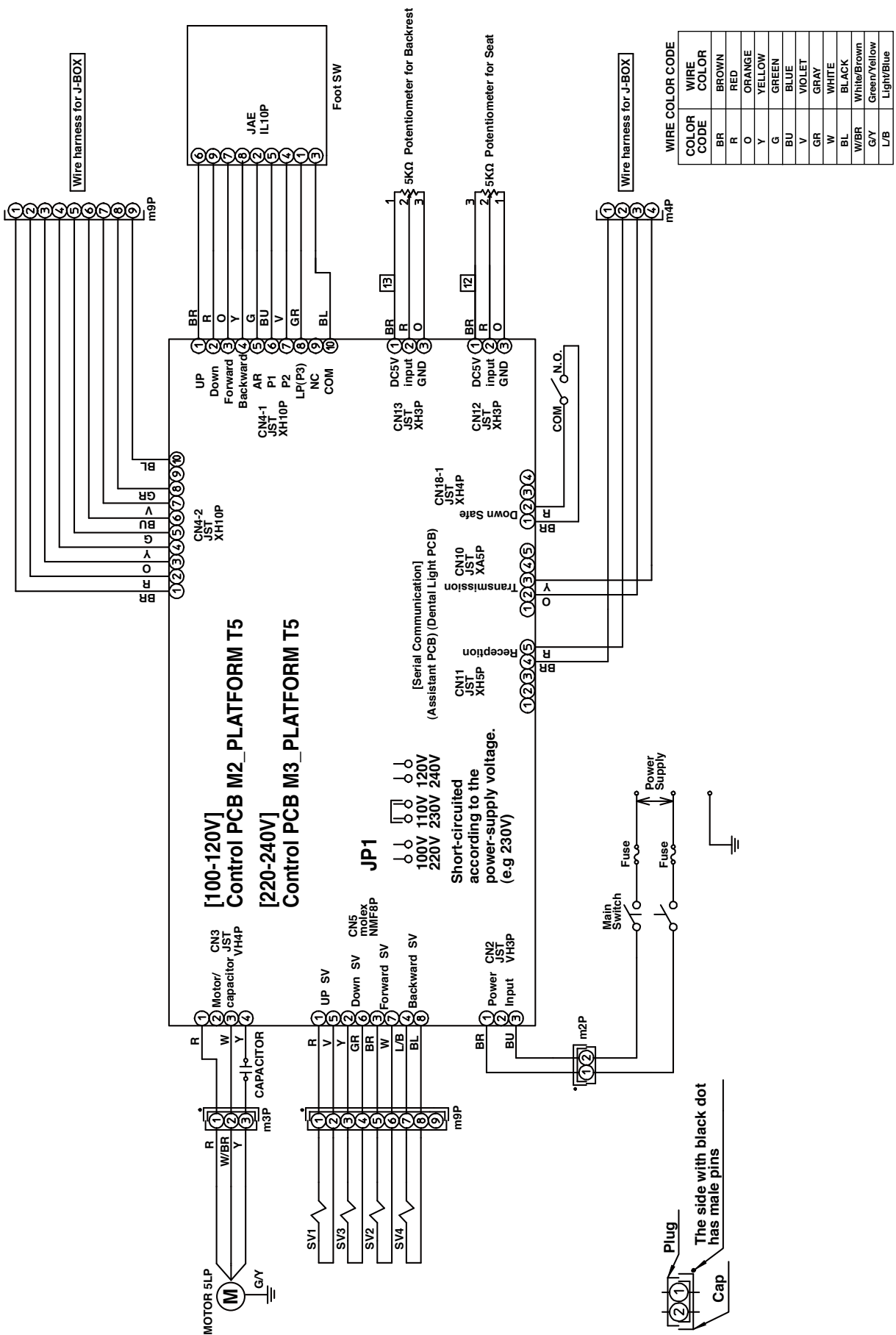

10. UNIT FLOW DIAGRAM

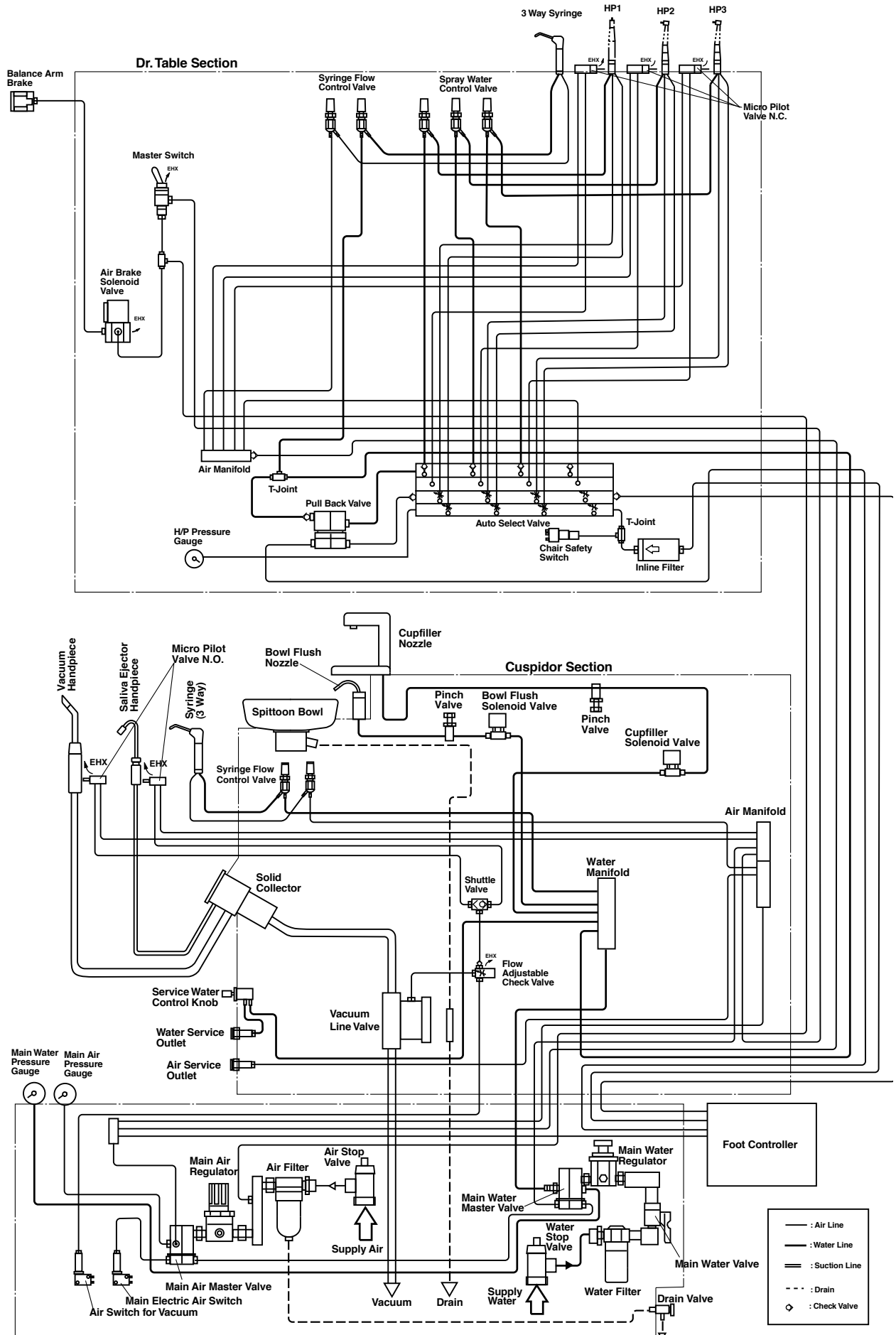

11-1. UNIT ELECTRICAL DIAGRAM (A Spec.)

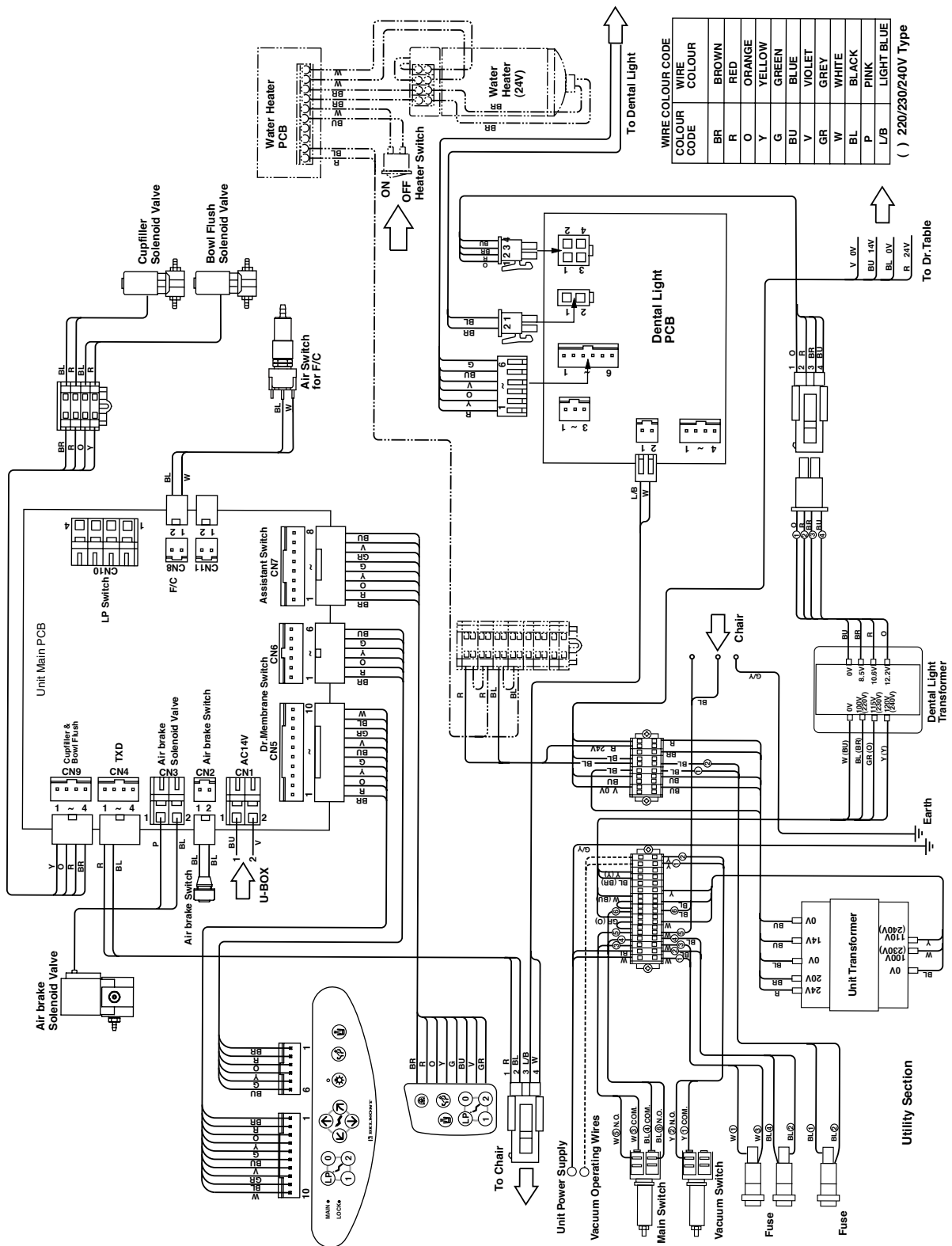

11-2. UNIT ELECTRICAL DIAGRAM (E Spec.)

Doctor Table Section

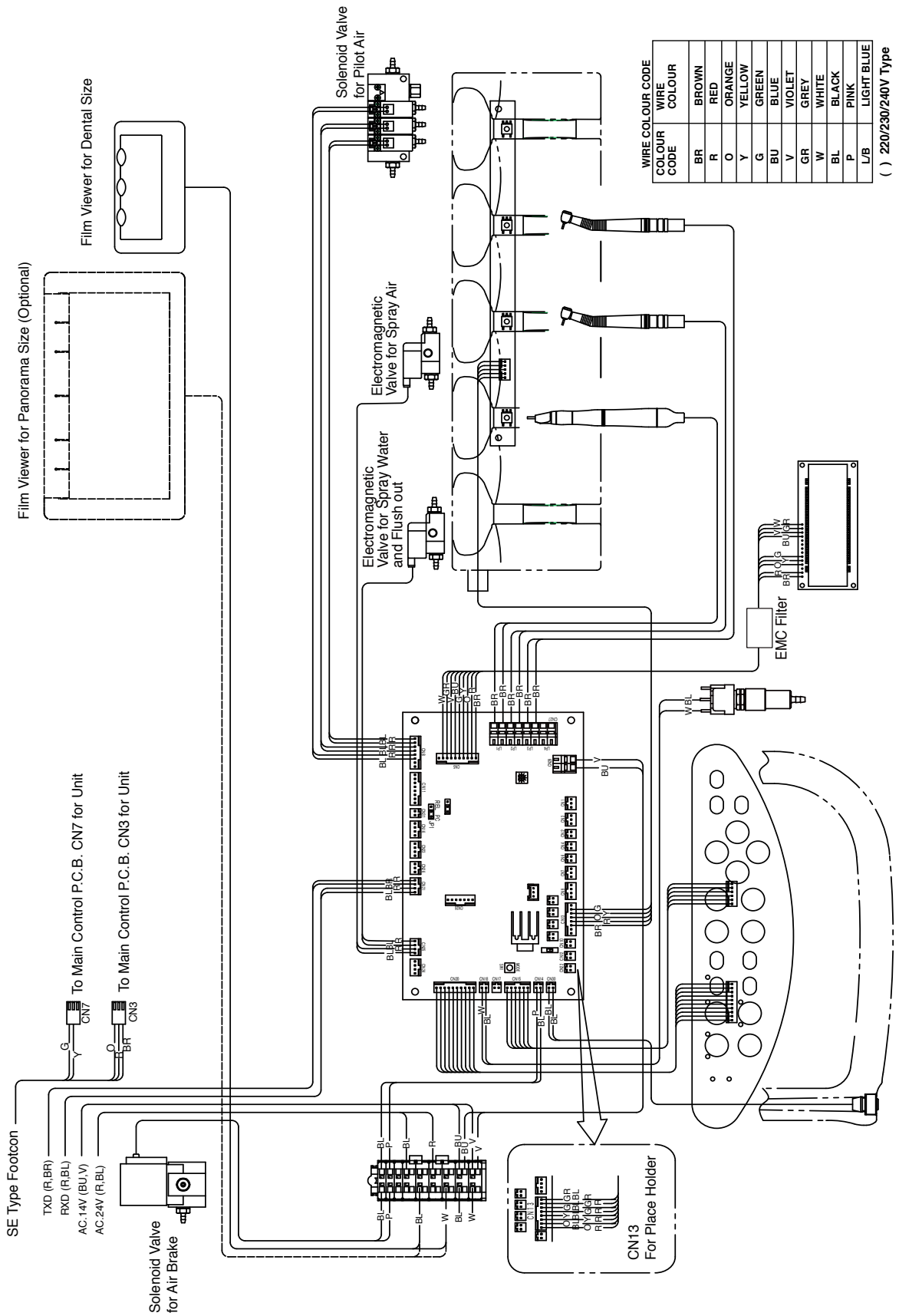

Cuspidor Section

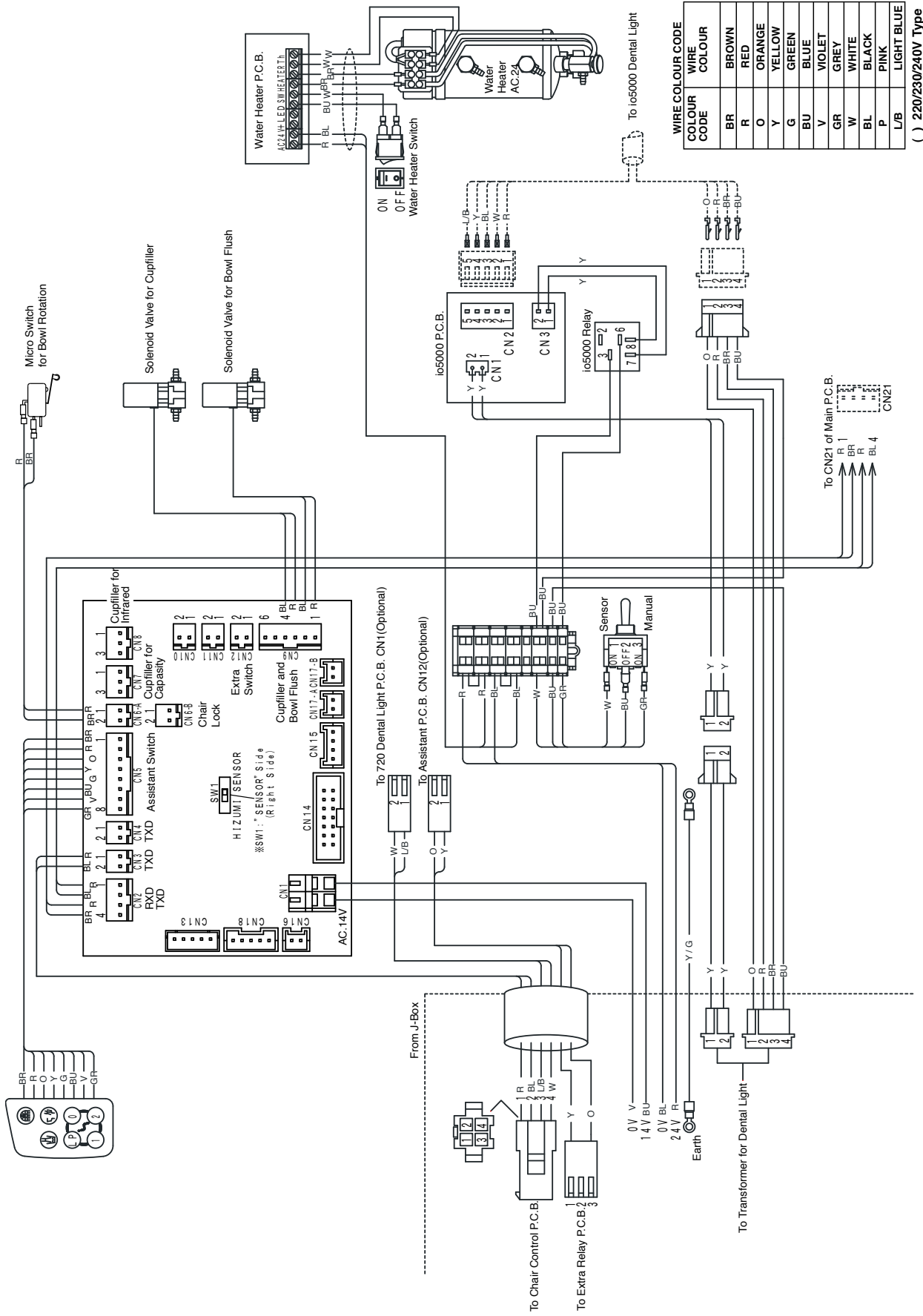

WIRE COLOUR CODE	WIRE COLOUR
BR	BROWN
R	RED
O	ORANGE
Y	YELLOW
G	GREEN
BU	BLUE
V	VIOLET
GR	GREY
W	WHITE
BL	BLACK
P	PINK
L/B	LIGHT BLUE

() 220/230/240V Type

Utility Section

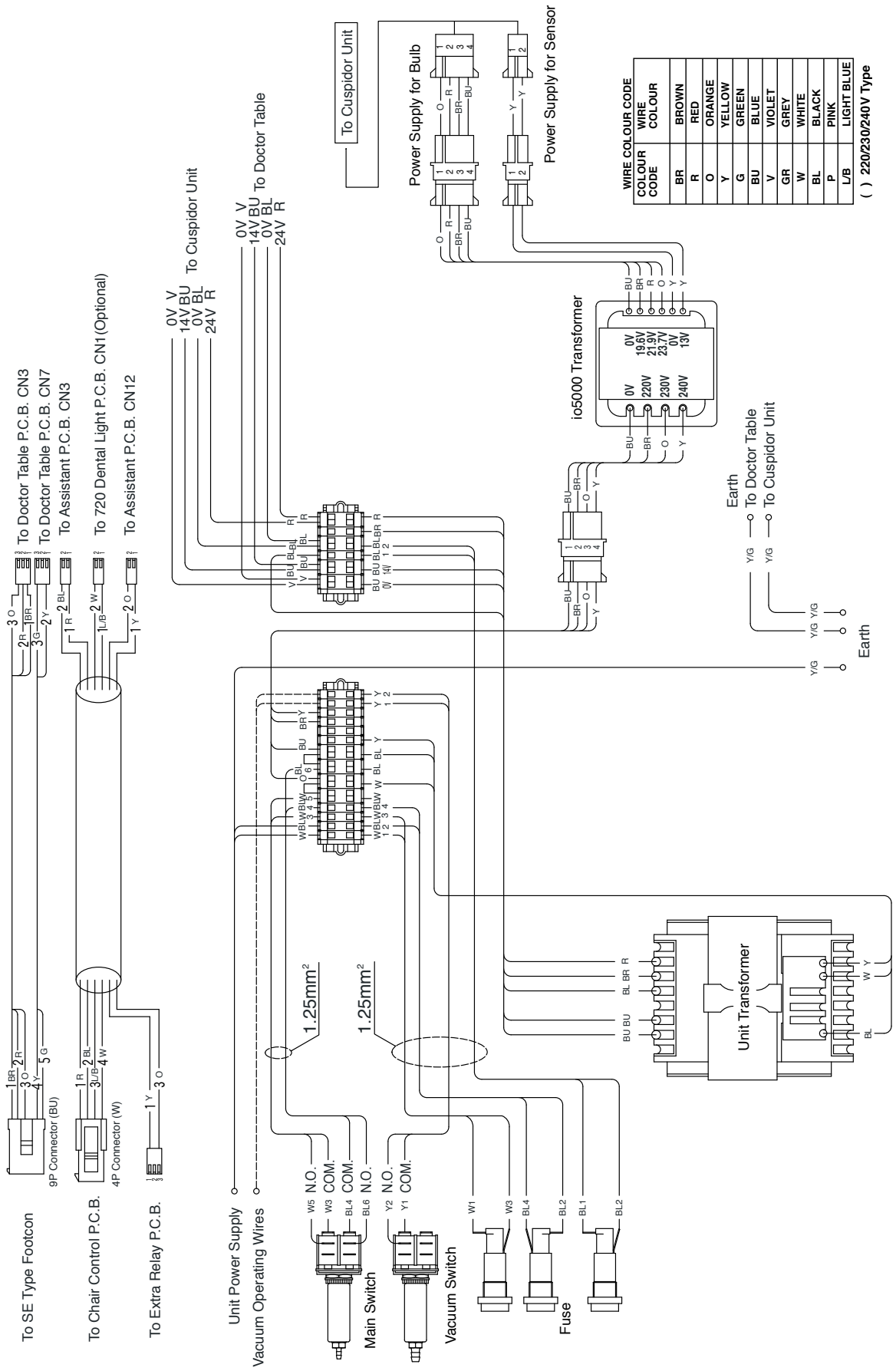

NOTE



TAKARA BELMONT CORPORATION

2-1-1, Higashishinsaibashi, Chuo-ku, Osaka, Japan

TEL : +81 6 6213 5945

FAX : +81 6 6212 3680

BOOK NO. FEGA02F0

Printed in Japan 2010-10